

Green Pin Sling Shackles Bow Type with Safety Nut and Bolt Pin

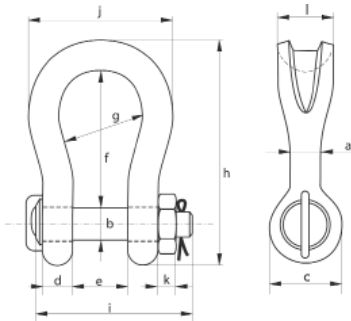

- Grade 8 Alloy steel body and pin, quenched and tempered.
- Minimum breaking load is 5 times the W.L.L.
- Shackle body silver painted, Pin green painted.
- Temperature range -20 ° C upto +200 ° C.
- At no extra charges this product can be supplied with a works certificate, certificate of basic raw material, manufacturer test certificate, EC Declaration of Conformity and all shackles are supplied with a Lloyd's Register of Shipping Certificate on proof load, a MPI certificate and US inspection certificate.
- ±5% forging tolerance on inside width and length



W.L.L tons	a mm	b mm	c mm	d mm	e mm	f mm	g mm	h mm	i mm	j mm	k mm	l mm	weight kgs
40	55	51	109	45	80	200	140	331	252	235	38	97	22
55	60	57	115	55	85	250	160	396	304	270	45	100	50
75	70	70	140	70	105	290	186	467	359	345	54	120	67
125	85	80	155	85	130	365	220	569	428	410	64	150	105
150	94	95	180	89	140	390	250	627	441	455	50	170	160
200	110	105	200	100	150	480	276	744	474	508	50	205	220
250	126	120	228	110	170	540	300	842	528	600	60	240	320
300	135	134	245	122	185	600	350	926	594	620	70	265	350
400	160	160	295	145	220	575	370	964	686	715	80	320	635
500	170	180	330	160	250	680	450	1107	763	810	90	340	803
600	190	200	350	170	275	740	490	1207	828	913	100	370	980
700	200	215	392	190	300	750	540	1257	878	993	100	400	1260
800	218	230	420	200	325	850	554	1395	959	986	110	420	1430
900	242	255	466	220	350	850	584	1454	1040	1050	120	440	1650
1000	260	270	490	240	380	855	614	1497	1116	1176	120	460	2120
1250	285	300	510	260	430	930	650	1620	1193	1275	150	530	2400
1500	295	320	550	280	460	950	680	1710	1278	1350	160	560	3600



George Taylor & Company Lifting Gear (Midlands) Ltd. Brickyard Road, Aldridge, West Midlands WS9 8SR

Telephone: 01922 457916 or visit: www.gtlifting.co.uk

ALL OFFERS ARE SUBJECT TO OUR CONDITIONS OF BUSINESS