

Green Pin Heavy Duty Bow Shackles with Safety Nut and Bolt Pin

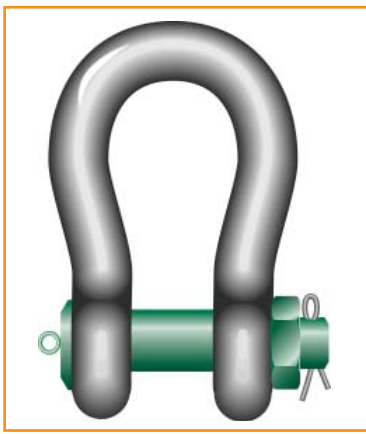

- Grade 8 Alloy steel body and pin, quenched and tempered.
- Proof load certificate supplied.
- Minimum breaking load is 5 times the W.L.L.
- 120ton hot dipped galvanised finish.
- 150ton and above are silver painted body and green painted pin.
- Forging tolerances +5% on inside width and inside length.
- All shackles from 150ton are supplied with Lloyds register of shipping proof load certificate.
- Marked with ID mark, size, W.L.L and manufacturers mark.

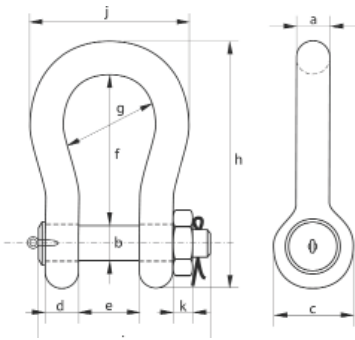

W.L.L tons	a mm	b mm	c mm	d mm	e mm	f mm	g mm	h mm	i mm	j mm	k mm	weight kgs
120	95	95	215	89	144	381	238	667	440	416	50	110
150	105	108	245	100	165	400	275	702	490	485	60	160
200	120	130	288	110	175	500	290	854	520	530	60	235
250	130	140	308	115	200	540	305	921	560	565	65	285
300	140	150	335	120	200	600	305	1018	575	585	70	340
400	170	175	387	160	225	650	325	1137	690	665	70	560
500	180	185	410	160	250	700	350	1213	710	710	70	685
600	200	205	458	185	275	700	375	1267	810	775	70	880
700	210	215	468	200	300	700	400	1287	850	820	70	980
800	210	220	478	200	300	700	400	1294	870	820	70	1100
900	220	230	500	210	320	700	420	1320	920	860	70	1280
1000	240	240	530	210	340	700	420	1360	940	900	70	1460
1250	260	270	600	225	360	700	450	1430	1020	970	70	1990
1500	280	290	640	225	360	700	450	1480	1060	1010	70	2400

Green Pin Heavy Duty Dee Shackles with Safety Nut and Bolt Pin

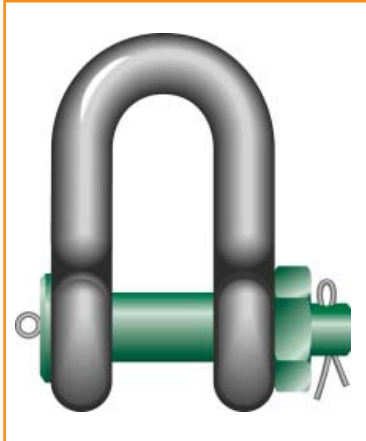

- Grade 8 Alloy steel body and pin, quenched and tempered.
- Proof load certificate supplied.
- Minimum breaking load is 5 times the W.L.L.
- Hot dipped galvanised finish.
- Green painted pin.
- Forging tolerances +5% on inside width and inside length.
- Marked with ID mark, size, W.L.L and manufacturers mark.

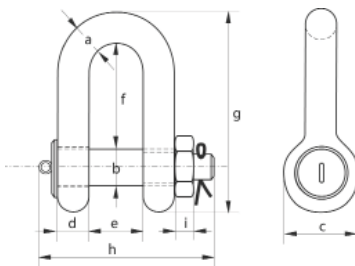

W.L.L tons	a mm	b mm	c mm	d mm	e mm	f mm	g mm	h mm	i mm	weight kgs
120	95	95	215	89	144	267	530	440	50	110



George Taylor & Company Lifting Gear (Midlands) Ltd. Brickyard Road, Aldridge, West Midlands WS9 8SR

Telephone: 01922 457916 or visit: www.gtlifting.co.uk

ALL OFFERS ARE SUBJECT TO OUR CONDITIONS OF BUSINESS