



# Operating Instructions

## Hand Pallet Truck Parts List



**NOTE:** Owner and operator **MUST** read and understand these operating instructions before using this pallet truck.

**George Taylor & Company Lifting Gear (Midlands) Ltd.**

Brickyard Road, Aldridge, West Midlands WS9 8SR

Telephone: 01922 457916 or visit: [www.gtlifting.co.uk](http://www.gtlifting.co.uk)

## **ATTENTION:**

1. The waste packages should be sorted and put into solid dustbins according to the materials and be collected for disposal by local special environment agencies. To avoid pollution, these items should not be thrown away disrespectfully.
2. To avoid leaking during the use of the products, the user should prepare some absorbable materials (scraps of wooden or dry duster cloth) to absorb the leaking oil in time. To avoid additional pollution to the environment, the used absorbable materials should be handed in to special departments in terms of local authorities.

Thank you for choosing our pallet trucks. for you safety and correct operation, please carefully read the manual before use.

**NOTE:** All of the information reported herein is based on data available at the time of printing. The factory reserves the right to modify its own products at any time without notice of liability in any sanctions. Please verify with the factory for possible updates and changes.

## 1. GENERAL SPECIFICATIONS

Capacity (kg)	2000	2000	2500	2500	3000	3000
Maximum Fork Height (mm)	200 (or 190)					
Minimum Fork Height (mm)	85 (or 75)					
Fork Length (mm)	1150	1220	1150	1220	1150	1220
Width Overall Forks (mm)	450 / 520 / 550 / 685					
Individual Fork Width (mm)	160					
Load Wheel Diameter (mm)	ø 80x70 (or ø 74x70) Nylon, Polyurethane					
Steering Wheel Diameter (mm)	ø 200 (or ø 180) Nylon, Polyurethane, Rubber					

Special fork lengths are available in 800, 900, 950, 1000, 1500, 2000mm.  
Materials and specifications are subject to change without notice.

## 2. ATTACHING HANDLE TO PUMP UNIT

- 2.1 Remove 3 bolts (D611 from the handle bracket (D151).
- 2.2 Set handle (D610A, D610B or D610AS) on the bracket (D151), notice to allow the chain (D612) and the adjusting bolts (D614) assembly to pas through the hole in the centre of the bracket (D151) and shaft (D153).
- 2.3 Insert the 3 bolts (D611) through the handle into the bracket (D151), then tighten them securely.
- 2.4 Raise the lever plate (D132) and insert the adjusting bolt (D614) into the front slot, keeping the adjusting nut (D615) on the unde side of the lever plate (D132).

## 3. ADJUSTING RELEASE DEVICE

On the draw-bar of this pallet truck, you can find the control handle (D608 or D608S) which can be adjusted in three positions :

Raise - handle down

Drive - handle in centre position

Lower - handiel up, the lever moves back the drive position when released.

If however they have been changed, you can adjust according to the following steps:

- 3.1 If the forks elevate while pumping in the **DRIVE** position, turn the adjusting nut (D615) on the adjusting bolt (D614) or adjusting screw (D133) clcokwise until pumping action does not raise the forks and the **DRIVE** position functions properly.
- 3.2 If the forks descend while pumping in the **DRIVE** position, turn the nut (D615) or adjusting screw (D133) counter-clockwise until the forks do not lower.
- 3.3 If the forks do not descend when the control handle (D608 or D608S) is in the **LOWER** position, turn the nut (D615) or adjusting screw (D133) clockwise until raising the control handle (D608 or D608S) lowers the forks. Then check the **DRIVE** position according to item 3.1 and 3.2 to be sure the nut (D615) or adjusting screw (D133) is in the proper position.
- 3.4 If the forks do not elevate while pumping in the **RAISE** position, turn the nut (D615) or adjusting screw (D133) counter-clockwise until the forks elevate while pumping in the **RAISE** position. Then check the **LOWER** and **DRIVE** position according to item 3.1, 3.2 and 3.3.

## 4. MAINTENANCE

Your pallet truck is largely maintenance-free.

### 4.1 OIL

Please check the oil level every six months. The oil capacity is about 0.3lt. Use the hydraulic type oil according to temperature scale below.

Temperature	Oil
-20°C ~ +40°C	L-HV46 Hydraulic oil

### 4.2 EXPELLING AIR FROM THE PUMP UNIT

The air may come into the hydraulic oil because of transportation or pump in upset position. It can cause the forks unable to elevate while pumping while in the **RAISE** position. the air may escape ini the following way: let the control handle (D608 or D608S) on the **LOWER** position, then move the handle (D610A, D610B or D610AS) up and down for several times.

### 4.3 DAILY CHECK AND MAINTENANCE

Daily check of the pallet truck can limit wear as much as possible. Special attention should be paid to wheels, azles, thread, rags, etc. It may block the wheels. The forks should be unloaded and lowered in the lowest position when the job is over.

### 4.4 LUBRICATION

Use motor oil or grease to lubricate all moveable parts.

## 5. GUIDE TO SAFETY OPERATIONS

For safe operation of the Hand Pallet Truck, please read all warning signs and instructions here and on the pallet truck prior to use.

- 5.1 Do not operate the pallet truck unless you are familiar with it and have been trained or authorised to do so.
- 5.2 Do not operate the truck unless you have been trained and authorised. Pay special attention to the wheels, the handle assembly, the forks and the lower control.
- 5.3 Do not use the truck on sloping ground.
- 5.4 Never place any part of your body in the lifting mechanism or under the forks or load. Do not carry passengers.
- 5.5 It is advisable that operators should wear gloves and safety shoes.
- 5.6 Do not handle unstable or loosely stacked loads.
- 5.7 Do not overlead the truck.
- 5.8 Always place loads centrally across the forks and not at the end of the forks (See Fig. 2).
- 5.9 The capacity of the truck assumes an evenly distributed load with the centre of the load being at the halfway point of the length of the forks.
- 5.10 Make sure that the length of the forks matches the length of the pallet.
- 5.11 Lower the forks to the lowest height when the truck is not being used.
- 5.12 In other specific conditions, the operators shold take extra care in operating the truck.

## 6. TROUBLE SHOOTING

No	Trouble	CAUSE	ACTION
1	The forks cannot be lifted up to the maximum height.	<ul style="list-style-type: none"> <li>The hydraulic oil is not enough.</li> </ul>	<ul style="list-style-type: none"> <li>Pour in the oil.</li> </ul>
2	The forks cannot be lifted up.	<ul style="list-style-type: none"> <li>Without hydraulic oil.</li> <li>The oil has impurities.</li> <li>The nut (D615) is too high or the screw (D133) is too close, keep the pumping valve open.</li> <li>Air comes into the hydraulic oil.</li> </ul>	<ul style="list-style-type: none"> <li>Fill in the oil.</li> <li>Change the oil.</li> <li>Adjust the nut (D615) or the screw (D133), (see item 3.4).</li> <li>Banish the air, (see item 4.2).</li> </ul>
3	The forks cannot be lowered.	<ul style="list-style-type: none"> <li>The piston rod (D147) or pump body is deformed resulting from partial loading slanting to one side or overloading.</li> <li>The fork was kept in the high position for a long time with piston rod bared to arise in rusting and jamming of the rod.</li> <li>The adjusting nut (D615) or the screw (D133) is not the correct position.</li> </ul>	<ul style="list-style-type: none"> <li>Replace the piston rod (D147) or pump body.</li> <li>Keeping the fork in the lowest position if not using, and pay more attention to lubricating the rod.</li> <li>Adjust the nut (D615) or the screw (D133), (see item 3.3).</li> </ul>
4	Leaks.	<ul style="list-style-type: none"> <li>Sealing parts worn or damaged.</li> <li>Some part cracked or worn into small</li> </ul>	<ul style="list-style-type: none"> <li>Replace with the new one.</li> <li>Replace with the new one.</li> </ul>
5	The forks towers without the release.	<ul style="list-style-type: none"> <li>The impurities in the oil cause the release valve to be unable to close tight.</li> <li>Some parts of hydraulic system is cracked or bored.</li> <li>Air come into the oil</li> <li>Sealing parts worn or damaged.</li> <li>The adjusting nut (D615) or the screw (D133) is not in the correct position.</li> </ul>	<ul style="list-style-type: none"> <li>Replace with new oil.</li> <li>Inspect and replace the waste parts.</li> <li>Banish the air, (see item 4.2).</li> <li>Replace with the new one.</li> <li>Adjusting the nut (D615) or the screw (D133), (see item 3.2).</li> </ul>

**\*NOTE: DO NOT ATTEMPT TO REPAIR THE PALLET TRUCK UNLESS YOU ARE TRAINED AND AUTHORISED TO DO SO.**

Fig. 1

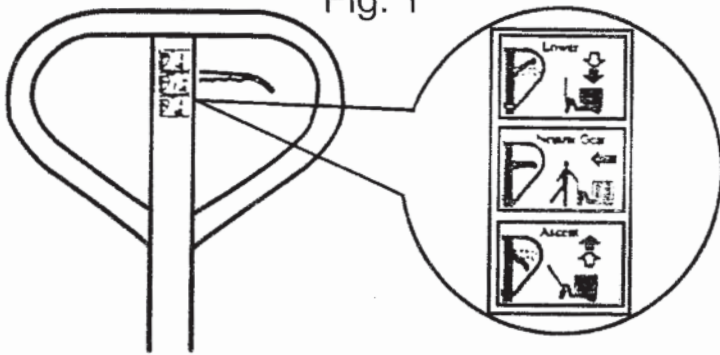
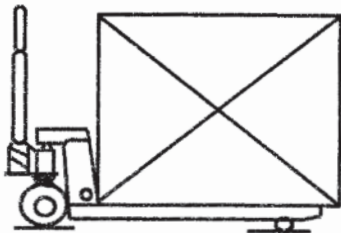
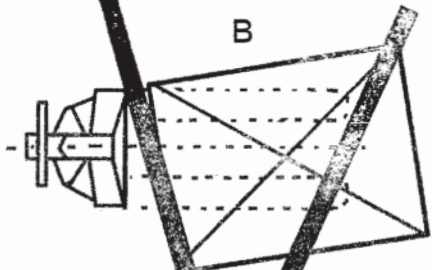
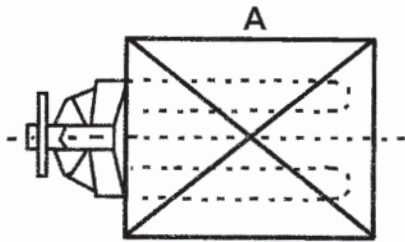
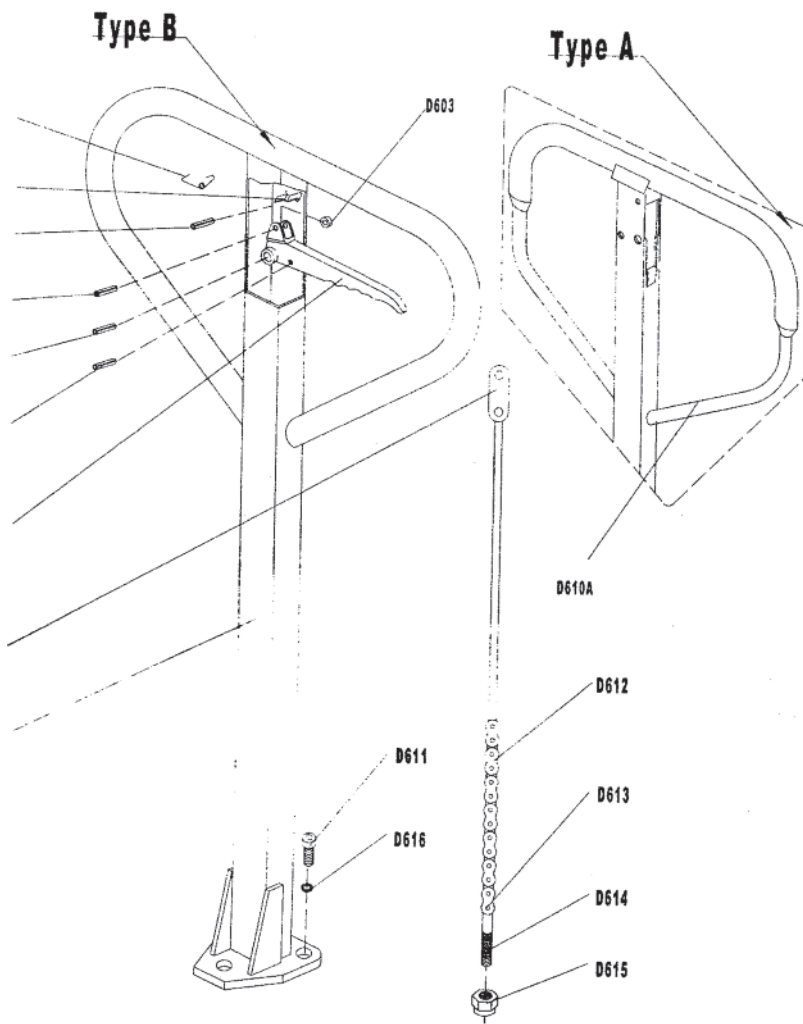

Fig. 2





### List of Handle

No.	Description	Qty.	Remark	No.	Description	Qty.	Remark
D601	Spring	1		D610A	Handle	1	For Type A
D602	Blade Spring	1		D610B	Handle	1	For Type B
D603	Roller	1		D611	Screw	3	
D604	Elastic Pin	1		D612	Chain	1	
D605	Elastic Pin	1		D613	Pin	1	
D606	Elastic Pin	1		D614	Adjusting Bolt	1	
D607	Elastic Pin	1		D615	Adjusting Nut	1	
D608	Control Handle	1		D616	Elastic Washer	3	
D609	Pull Board	1					

# Type D

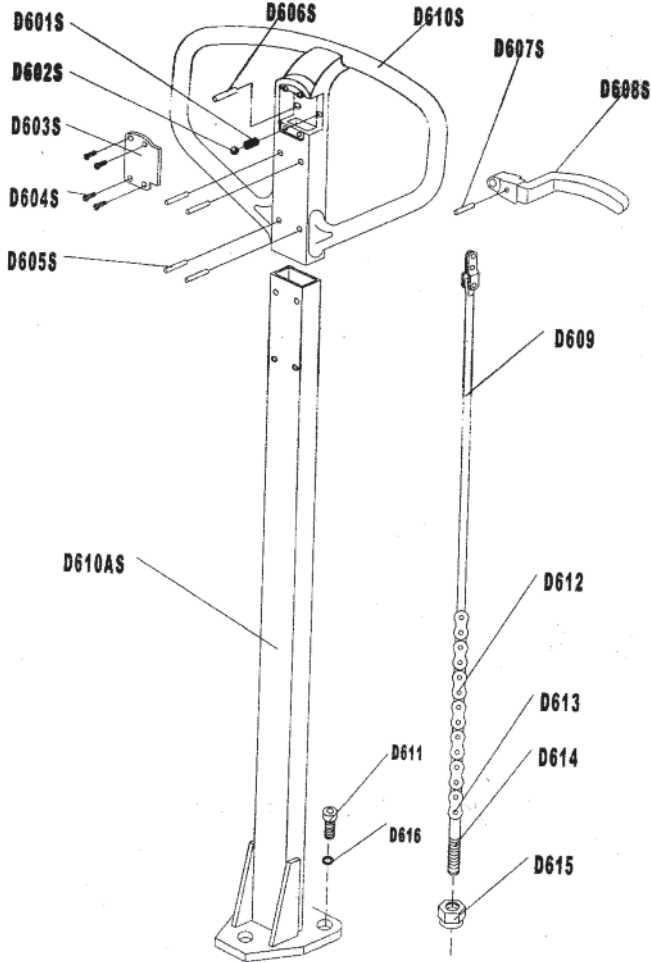

## List of Handle

No.	Description	Qty.	Remark	No.	Description	Qty.	Remark
D601S	Spring	1	Only for Type D	D610S	Handle	1	Only for Type D
D602S	Steel Ball	1		D610AS	Draw-bar	1	
D603S	Cover	1		D611	Screw	3	
D604S	Screw	4		D612	Chain	1	
D605S	Pin	4		D613	Pin	1	
D606S	Pin	1		D614	Adjusting Bolt	1	
D607S	Elastic Pin	1		D615	Adjusting Nut	1	
D608S	Control Handle	1		D616	Elastic Washer	3	
D609S	Pull Board	1					

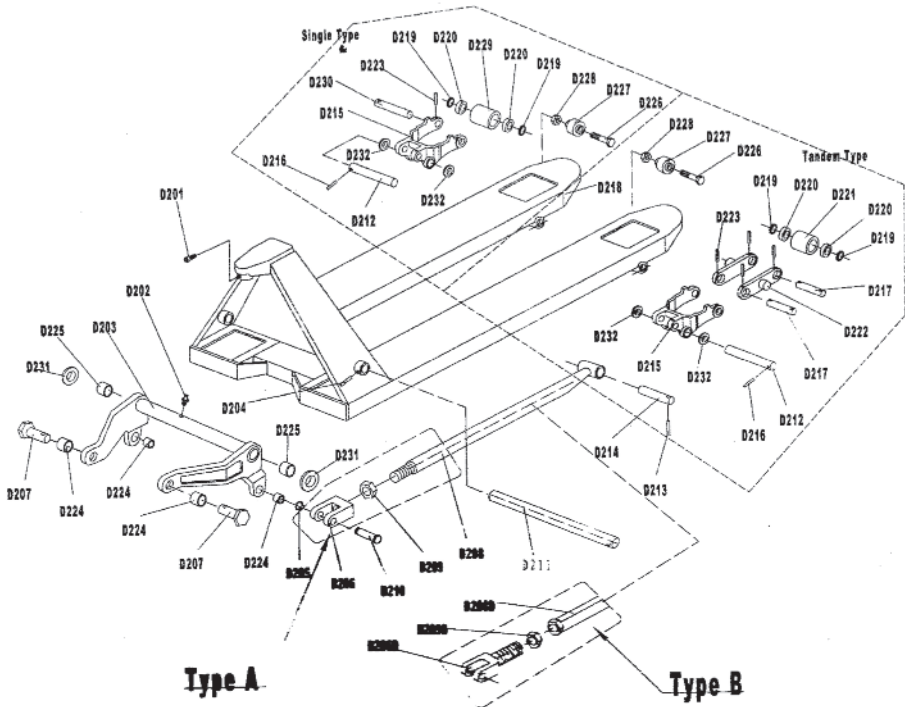

**List of Fork Frame**

No.	Description	Qty.	Remark	No.	Description	Qty.	Remark
D201	Screw	1		D216	Elastic Pin	2	
D202	Oil - holder	1		D217#	Shaft for Roller	4	
D203	Rock - arm	1		D218	Fork Frame	1	
D204	Elastic Pin	1		D219	Washer	8 or 4	
D205	Retaining Ring	2		D220	Bearing	8 or 4	
D207	Shaft	2		D221#	Loading Roller	4	
D206	Joint	2	<b>ONLY for Type A</b>	D222	Linking Plate	4	
D208	Pushing Rod	2		D223	Elastic Pin	8 or 2	
D209	Nut	2		D224	Bushing	4	
D206D	Joint	2	<b>ONLY for Type B</b>	D225	Bushing	2	
D208D	Pushing Rod	2		D226	Bolt	2	
D209D	Nut	2		D227	Enter Roller	2	
D210	Pin	2		D228	Nut	2	
D211	Shaft	1		D229*	Loading Roller	2	
D212	Shaft	2		D230*	Shaft for Roller	2	
D213	Elastic Pin	2		D231	Washer	2	
D214	Shaft	2		D232	Washer	4	
D215	Frame of Roller	2					

# PUMP

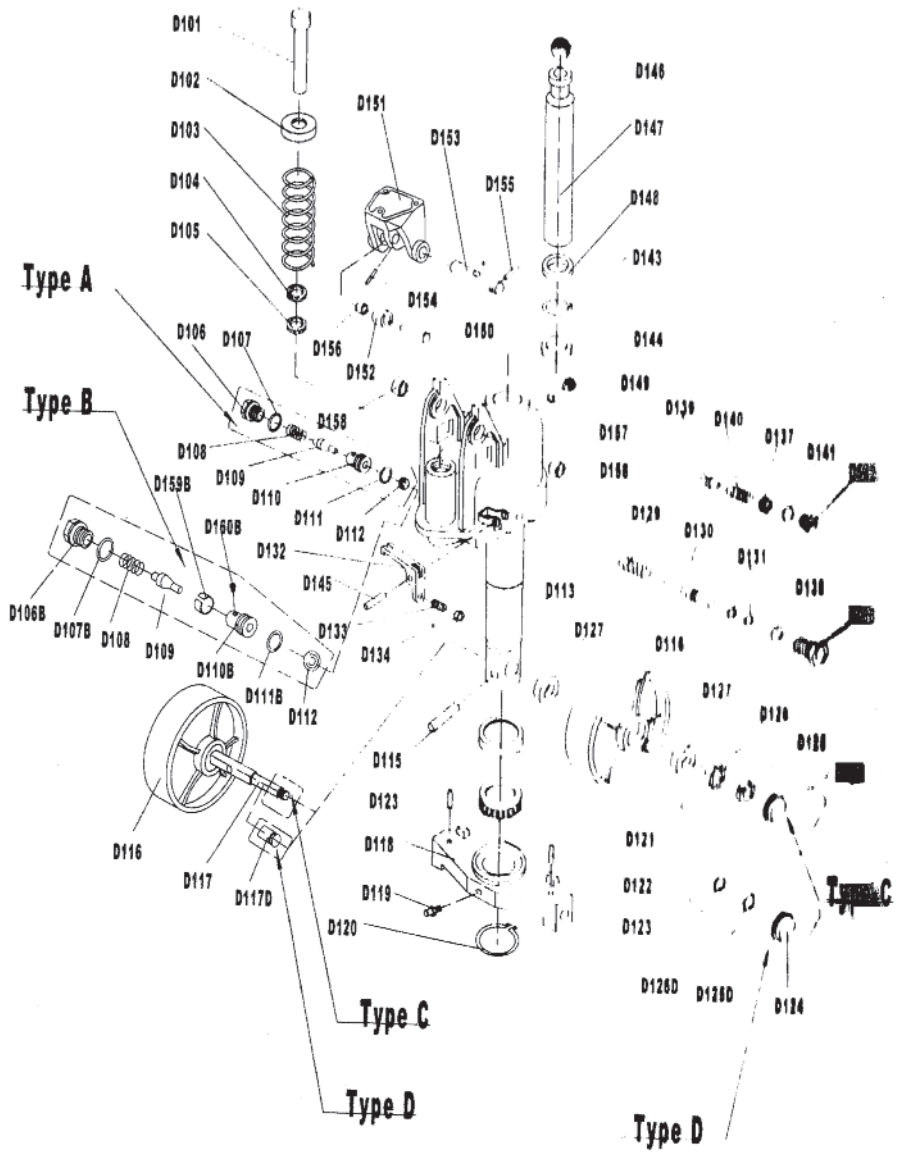

## List of Pump Unit

No.	Description	Qty.	Remark
D101	Pump Piston Rod	1	
D102	Washer	1	
D103	spring	1	
D104	Dust Ring	1	
D105	Y - Seal	1	
D108	Spring	1	
D109	Spindle of Pumping Valve	1	
D112	Steel Ball	1	
D106	Screw	1	
D107	O - Ring	1	<b>ONLY for Type A</b>
D110	Seat of Pumping Valve	1	
D111	O - Ring	1	
D106B	Screw	1	
D107B	O - Ring	1	<b>ONLY for Type B</b>
D110B	Seat of Pumping Valve	1	
D111B	O - Ring	1	
D159B	Sleeve	1	
D160B	Screw	1	
D113	Base of Pump	1	
D115	Elastic Pin	1	
D116	Steering Wheel	2	
D118	Thrust Plate	1	
D119	Oil - holder	1	
D120	Retaining Ring	1	
D121	Cover of Bearing	1	
D122	Bearing	1	
D123	Elastic Pin	2	
D124	Dust Cover	2	
D117	Shaft of Steering Wheel	1	<b>ONLY for Type C</b>
D125	Round Nut	2	
D126	Tab Washer	2	
D117D	Shaft of Steering Wheel	1	<b>ONLY for Type D</b>
D125D	Retaining Ring	2	
D126D	Tab Washer	2	
D127	Bearing	4	
D129	Spring	1	
D130	Strike Pin	1	
D131	O - Ring	2	
D132	Lever Plat	1	
D133	Adjusting Screw	1	
D134	Nut	1	
D135	O - Ring	1	
D136	Axle Sleeve	1	
D137	Adjusting Bolt	1	
D139	Spindle of Safety Valve	1	
D140	Spring	1	
D141	O - Ring	1	
D142	Screw	1	
D143	O - Ring	1	
D144	Y - Seal	1	
D145	Elastic Pin	1	
D146	Steel Ball	1	
D147	Piston Rod	1	
D148	Dust Ring	1	
D149	Screw	1	
D150	Shaft	1	
D151	Bracket	1	
D152	Pressure Roller	1	
D153	Shaft	1	
D154	Elastic Pin	1	
D155	Elastic Pin	1	
D156	Bushing	1	
D157	Seal Washer	1	
D158	Bushing	2	

# Option: Foot Brake

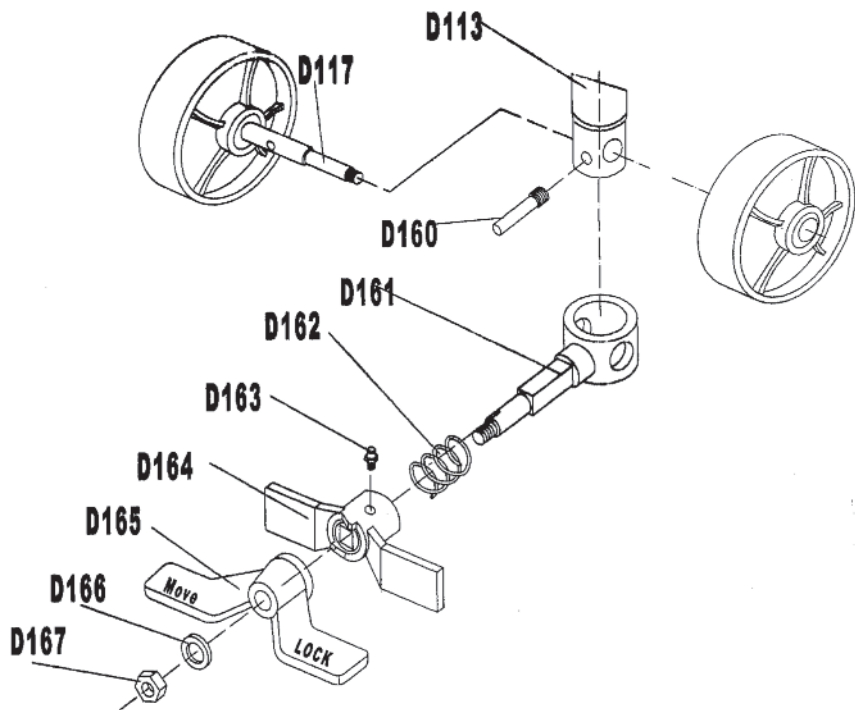

No.	Description	Qty.	No.	Description	Qty.
D117	Shaft of Steering Wheel	1	D163	Oil-Holder	1
D113	Pump Body	1	D164	Brake Plate	1
D160	Pin	1	D165	Pedal	1
D161	Holding Sleeve	1	D166	Washer	1
D162	Spring	1	D167	Nut	1

