



# Instruction Manual

## FM180



**NOTE:** Owner/Operator must read and understand this instruction manual before using the mover.

**George Taylor & Company Lifting Gear (Midlands) Ltd.**  
Brickyard Road, Aldridge, West Midlands WS9 8SR  
Telephone: 01922 457916 or visit: [www.gtlifting.co.uk](http://www.gtlifting.co.uk)

# **Contents**

- 1. Application**
- 2. Specifications**
- 3. Assembly**
- 4. Precautions and Preparation**
- 5. Operation**
- 6. Care and Maintenance**
- 7. Parts Lists & Exploded Figures**

THANK YOU VERY MUCH FOR CHOOSING OUR HYDRAULIC FURNITURE MOVER. FOR YOUR SAFETY AND CORRECT OPERATION, PLEASE CAREFULLY READ THE MANUAL BEFORE USE.

NOTE: All of the information reported herein is based on data available at the time of printing. The factory reserves the right to modify its own products at any time without notice or incurring in any sanction. Please verify with the manufacturer for possible updates.

## **1. Application**

The manual furniture mover has been developed for the lifting and transporting of cabinets and other large regular objects. For this reason, its supports are lined with foam rubber to prevent the goods being transported from becoming damaged.

Since the hydraulic furniture mover consists of two units, rectangular objects of varying length can be moved using a minimum of space. Due to the weight of the steel cabinet on the platform, it will hold itself in position when the units are standing vertically and the frame of the platform is in contact with its sides.

The securing strap, which has to be fastened correctly on both sides, is an additional absolute necessity.

The steering handles have a full lock of 180°, this meaning that goods being transported may be moved in every direction. The platforms are raised by operating the lever of the pump; this lever must not be used for pulling or pushing the BIMOBIL. The goods transported are lowered by twisting the manual release valve on the compact hydraulic system to the left. Great care must be taken when lowering the platform, since the speed depends on the aperture of the valve as well as the weight of the goods to be transported. Before pumping up the system to raise the platforms, the valve must be twisted to the right until the stopper allows you to close it.

Using an old crate, try a few “dry runs” with the transport units moving furniture with them.

If you operate properly, our hydraulic furniture mover will help you to move cabinets, furniture etc quickly and safely.

## 2. Specifications

Model	Capacity	Lifting Height	Lifting Plate Size	Net Weight
FM180A	1800kg	100mm	600×60mm	80kg
FM180B		250mm		86kg

## 3. Assembly

Remove the fork pin at the free end of the track rod, set the steering handles parallel to each other, and push the fork of the track rod over the arm of the steering handle. Then replace the previously- removed fork pin through the fork and arm and secure it with a clip.

The second unit is assembled in the same way.

## 4. Precautions and Preparation

4.1 The floor must be absolutely level, smooth and clean. There must be no inclines or slopes to be moved over. Make sure that the floor and the floor covering, are able to stand up to the loading imposed by the wheel and ensure they can take the weight of the furniture being transported.

4.2 Check whether the piece of furniture to be transported contains any loose objects. These will have to be removed, or secured to stop them slipping out of position.

4.3 Check whether the piece of furniture is strong enough for the two opposite sides to take the weight of the piece via the transport units' platforms, and whether the upper supports of the transport units can hold the furniture to be transport without damaging it.

4.4 Find the weight of the piece of furniture to be transported. The maximum load of 1800 kg/pair =900 kg for each unit must not be exceeded.

4.5 Find the centre of gravity of the furniture to be transported. Along the furniture base, it is decisive for the load that a single transport unit can bear, across the base, the centre of the transport unit, and, in connection with the height, for the moment of tilting that occurs when moving the furniture. When in use, the height of the centre of gravity must not exceed 0.8m. The distance of the transport units to one another must not be less than 0.5m and not exceed 4.0m.

4.6 Never use this equipment for towing behind a vehicle.

## **5. Operation**

Before use, the transport components should be checked for function, and for any damage. If there are visible defects, the components should not be used. Damaged parts must be replaced. Since the hydraulic furniture mover consists of two parts, it is necessary for two persons to operate them.

Before using the platforms should be let down to the floor until the transport units are standing vertically.

Push the platform of the units under the side faces (narrow faces) of the cabinet until the top and bottom of the transport platform frame are resting against it. The centres of the platform must be beneath the centre of gravity of the cabinet.

Place the securing straps in position and tighten them. The straps will connect both units and, when used correctly, prevent them from slipping out of their position holding the goods to be transported. Here, the strap ends must be under direct tension, that is, the straps must not be pulling round the edge of a cabinet, etc. If the position of the centre of gravity makes it necessary for the cabinet being

transported to project on one side out of frame, or, due to its width, it projects on both sides, an additional strap surrounding it must be employed. This must be fed through the strap loops on the units. However, the maximum overhang must not be more than 200 mm.

Pump up the platform about 1 cm, and carefully check how firmly the cabinet to be transported is standing on the platforms. It may be that the transport units will have to be moved to another position.

Both platforms must be raised at the same time and to the same amount. For the transport itself, the height off the floor must be a maximum of 2 cm only. When moving the cabinets, only push the transport units and choose the way to the cabinet's new position so that, if possible, it is only moved lengthwise. When moving cabinets sideways, always take the greatest care; there is a great risk of the cabinets tilting over. Avoid any pushing movements.



The cabinet being transported must not be left unattended standing on the equipment; it must always be lowered onto the floor.

The securing straps may only be opened when the cabinet being transported, or the platforms, is standing on the floor.

Never use this equipment for towing behind a vehicle.

## **6. Care and Maintenance**

Our hydraulic furniture mover only requires little care and maintenance, but this must be carried out regularly. Depending on its use, the spindles and gear wheels must be re-greased weekly or monthly, using standard multi-purpose grease. For this, the spindle may be reached using a brush through the slot in the guide rail. The gear wheels are also greased using brush, by first levering off the gear-housing lid with a screwdriver. The lid should be pressed down firmly to close it again. The units' function should be tested.

## 7. Parts Lists & Exploded Figures

### 7.1 For Lifting Height of 100mm

Item No.	Description	Qty
1	Dust-proof Cover	4
2	Cushion	2
3	Woven Stripe	1
4	Lifting Frame	1
5	Split Ring 8	1
6	Handle Assy.	1
7	Hand Grip	1
8	Synchronous Rod	2
9	Hydraulic Jack	1
10	Fixing Pin( I )	2
11	Spilt Ring 6	2
12	Fixing Pin ( II )	1
13	Cylindrical Spring Pin	2
14	Nylon Washer	2
15	Supporting Frame	1
16	Bolt M6×20	2
17	Supporting Rod	2
18	Bolt M10×70	2
19	Cargo Lashings	1
20	Nut M10	2
21	Thrust Bearing 51204	2
22	Dust-proof Ring	2
23	Bolt M12×90	2
24	Wheel	2
25	Liner Bushing	4

26	Axle Sleeve	2
27	Nut M12	2

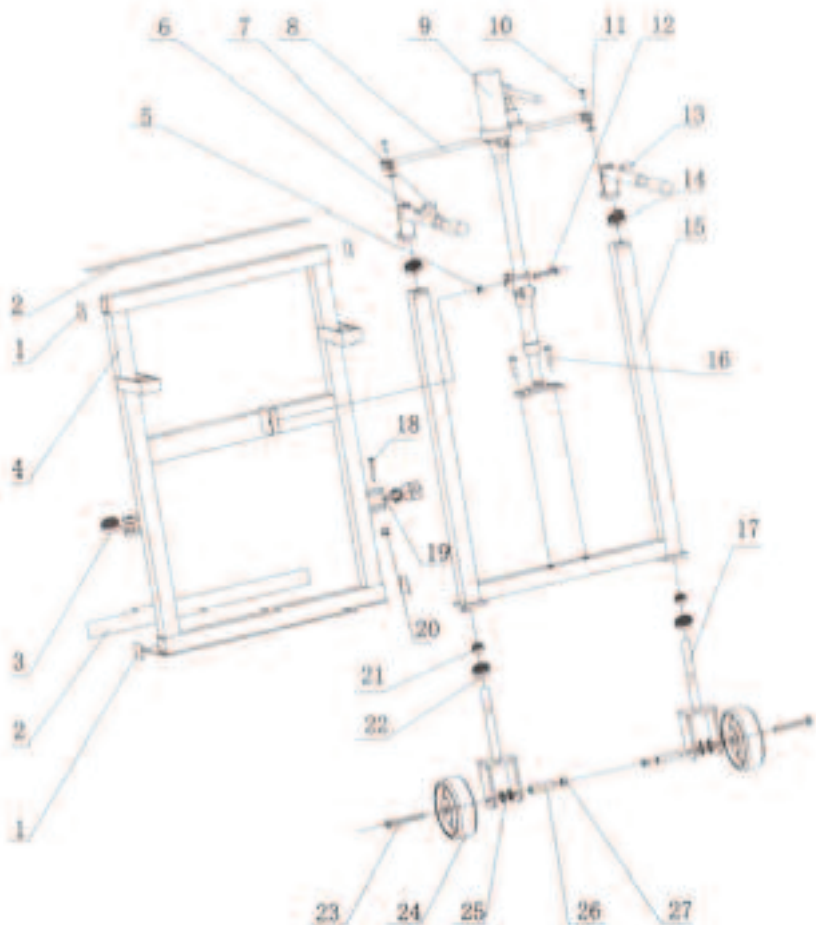

## 7.2 For Lifting Height of 250mm

<b>Item No.</b>	<b>Description</b>	<b>Qty</b>
1	Dust-proof Cover	4
2	Cushion	2
3	Woven Stripe	1
4	Lifting Frame	1
5	Split Ring 8	1
6	Handle Assy.	2
7	Hand Tube	1
8	Washer	2
9	Hydraulic Jack	1
10	Pin	2
12	Fixing Pin ( II )	1
13	Cylindrical Spring Pin	2
14	Nylon Washer	2
15	Supporting Frame	1
16	Bolt M6×20	2
17	Supporting Rod	2
18	Bolt M10×70	2
19	Cargo Lashings	1
20	Nut M10	2
21	Thrust Bearing 51204	2
22	Dust-proof Ring	2
23	Bolt M12×90	2
24	Wheel	2
25	Liner Bushing	4
26	Axle Sleeve	2
27	Nut M12	2

